

## Quote Information

1. Mold Opening (daylight, max is 24"): \_\_\_\_\_
2. (A) Width between Tie Rods: \_\_\_\_\_
3. (B) Width between Frame: \_\_\_\_\_
4. (C) Clearance Height (chute): \_\_\_\_\_
5. (D) Machine Clearance mold to base: \_\_\_\_\_
6. (E) Base to floor: \_\_\_\_\_
7. (F) Width of base: \_\_\_\_\_
8. (G) Desired extension past base: \_\_\_\_\_
9. (H) Desired discharge height: \_\_\_\_\_
10. Size of parts:  
Length: \_\_\_\_\_ Width: \_\_\_\_\_ Height: \_\_\_\_\_
11. Runner system:             Yes     No
12. If yes Runner system, runner size is:  
Length: \_\_\_\_\_ Width: \_\_\_\_\_ Height: \_\_\_\_\_
13. Do you require high temp material?  
(for parts over 180°)     Yes     No
14. Quantity: \_\_\_\_\_

**All dimensions must be completed for a Quote to be given.**

**Note:** All guideskirts come with mounting hardware. Standard color is Gray. Yellow can be requested at no extra charge. Please specify when ordering.

Soft Chutes have a material bottom only.

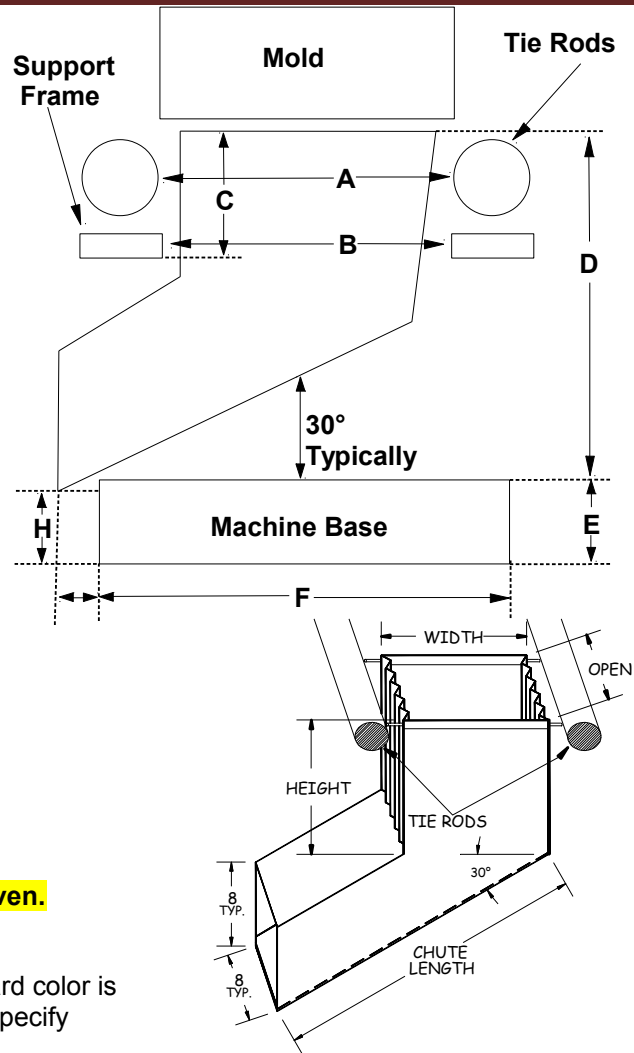

## Contact Information

Company Name \_\_\_\_\_  
 Contact Person \_\_\_\_\_  
 Address \_\_\_\_\_  
 \_\_\_\_\_  
 City, State, Zip \_\_\_\_\_  
 Phone ( ) - \_\_\_\_\_ ext: \_\_\_\_\_  
 Fax ( ) - \_\_\_\_\_  
 E-mail \_\_\_\_\_

**Please Fax to (815)337-3020 or  
E-mail to [sewing@macautomation.com](mailto:sewing@macautomation.com)**