

THE EXPERT IN "PARTS MANAGEMENT SYSTEMS"

Tie Bar Sleeves

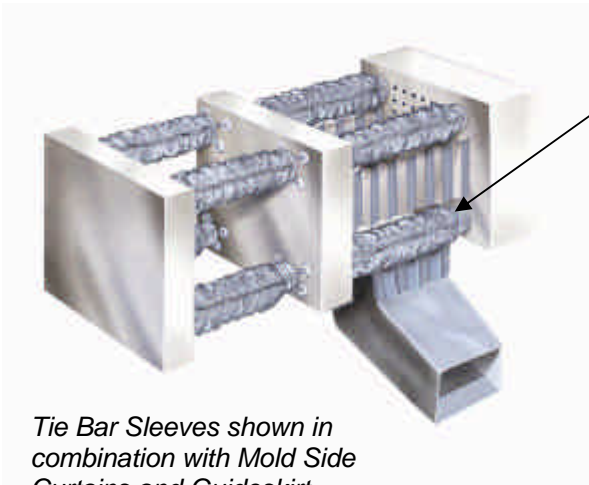

Tie Bar Sleeves shown in combination with Mold Side Curtains and Guideskirt

Tie Bar Sleeves - Inexpensive method to reduce contamination of molded parts while extending the life of tie bars and bushings.

Features zipper, Velcro, and magnetic mounting kit for quick and easy installation. Prevents molded parts from contacting tie bar grease.

Features:

- Protect tie bars and bushings from abrasive airborne particulates.
- Constructed of Nitrile coated cotton fabric.
- Custom made to any tie bar diameter.
- Provides a cleaner, more professional appearance at the press.
- Sized to the molding press, not individual molds.
- Opens and closes with mold stroke to provide continuous protection.
- Comes standard with magnetic mounting kit.

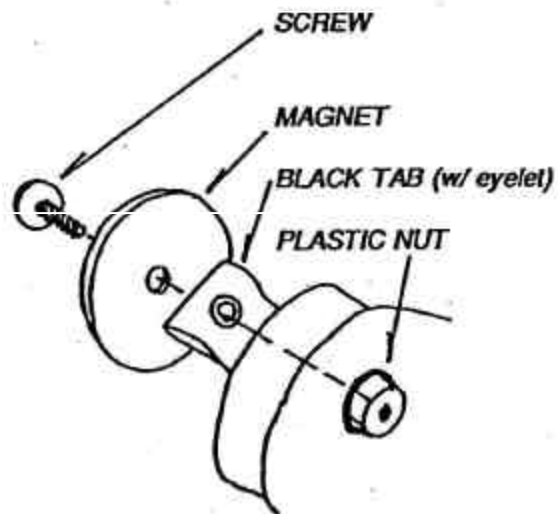

Shown in extended mold open position



Mold closed position



1760 Kilkenny Court
Woodstock, IL 60098
Phone: 815-337-3000
Fax: 815-337-3020
E-mail: sales@macautomation.com
www.macautomation.com

ORDER FORM ON BACK

THE EXPERT IN "PARTS MANAGEMENT SYSTEMS"

Tie Bar Sleeves

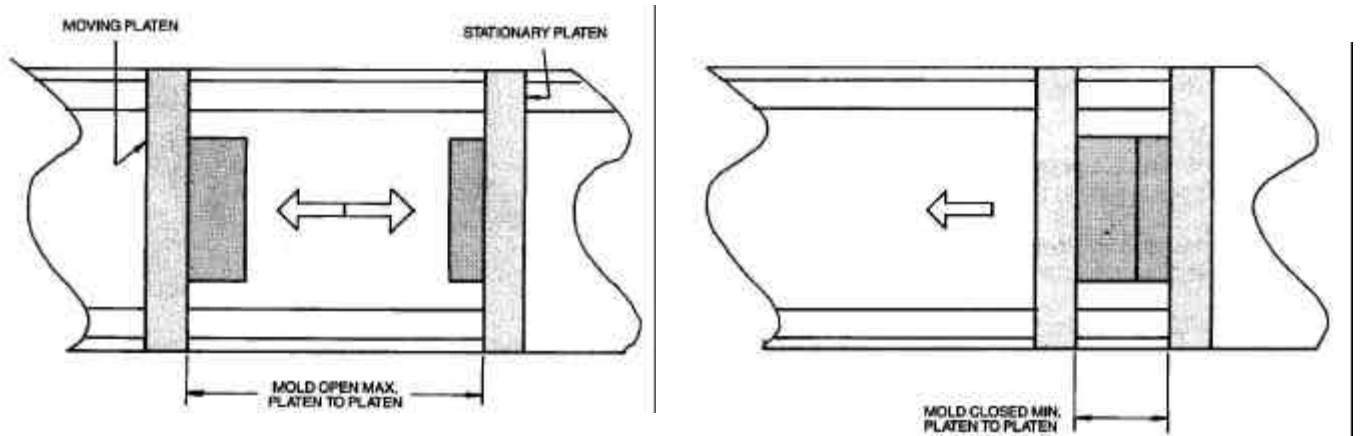

Note: 1½' clearance required between mold and tie bar.

MOLD OPEN: _____

MOLD CLOSED: _____

TIE BAR DIA.: _____

QUANTITY: _____

Please fax to 815-337-3020

Attn: Laura Ryan

COMPANY NAME: _____

CONTACT PERSON: _____

ADDRESS: _____

CITY: _____ STATE: _____ ZIP: _____

PHONE: _____ FAX: _____

E-MAIL: _____

✧ 1760 Kilkenny Ct.
Woodstock, IL 60098

✧ Ph: 815-337-3000
Fx: 815-337-3020

✧ sales@macautomation.com
www.macautomation.com