

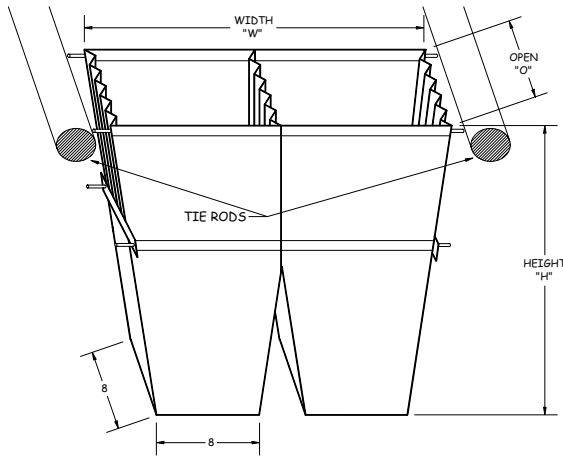

The Expert in "Parts Management Systems"

Split Leg Guideskirt – Quote Request Form

1. Mold Opening (daylight): _____
2. (A) Width between Tie Rods: _____
3. (B) Width between Frame: _____
4. (C) Chute height: _____
5. (D) Split, 3" standard: _____
6. Do you require high temp material: No Yes (for parts over 180°)
7. Quantity: _____

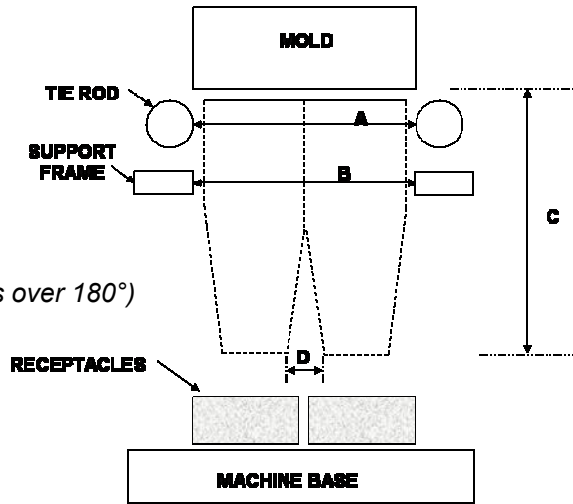

ALL dimensions must be completed in order for a Quote to be given.

All guideskirts come with mounting hardware. Hardware includes straight brackets (for attaching to side of mold) and right angle brackets (for mounting below the mold).

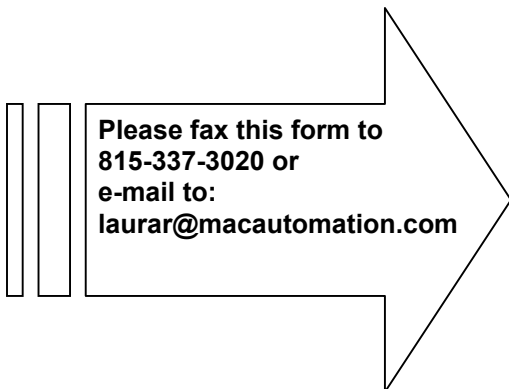

Please fax this form to
815-337-3020 or
 e-mail to:
laurar@macautomation.com

Company Name _____

Contact Person _____

Address _____

City, State, Zip _____, _____, _____

Phone, Fax () - , () - _____

E-mail @ _____