

## THE EXPERT IN "PARTS MANAGEMENT SYSTEMS"

### Steel Conveyor: Small Frame Series with Cleated



The "Small Frame Cleated Belt" conveyor series is a profile that is used for light weight finished part applications. This conveyor is ideally suited for under or beside press applications of small to medium sized injection molding machines, general purpose light weight parts. Other uses are plastic runner feeds into granulators. The fully welded construction of this model produces a solid, square frame for industrial use.

#### Specifications:

Lengths available: 3' to 15' lengths increments on 1' lengths  
Widths: 6" – 36" on increments

**Note: Special widths on 2" increments and special lengths on 6" increments are available.**

#### Common Options:

- Casters: Two-was, toe locking swivel casters with 4" diameter polyurethane wheels
- Variable speed drives: AC and DC type variable speed drive packages for different input voltages
- Belts: Wide selection of various belt materials, cleat sizing and spacing
- Indexing Packages: Automatic belt indexing packages
- Side Rails: Alternative side rail height and materials
- Covers for Top of Conveyors: Polycarbonate & stainless steel cover
- Covers for Bottom of Conveyors: Bottom covers painted steel & stainless steel
- Conditioning Units: Ambient air blowers and chilled water fed cooling blowers
- Many others - please inquire

#### Exclusive Series Features:

- Frame: Formed C-channel steel frame with welded cross members
- Castings: Supports bearings and pulleys, featuring a unique design for easy service and belt tracking adjustments
- Side Rail Overlap: Recessed belt edges, .335" per side, provide tight belt to rail tolerance
- Cleated Belt: Standard polyurethane belts with either 20, 30, 40, 60 mm tall cleats on 15" centers
- Pulleys: Feature a machined trapezoidal crowned on head and tail which provides increased tracking signal
- Motor Starter: Includes manual push button with thermal overload
- Hole pattern: Pre-punched pattern on bottom of frame for repositioning leg supports along the frame length
- Warranty: Two year limited



1760 Kilkenny Court  
Woodstock, IL 60098  
Phone: 815-337-3000  
Fax: 815-337-3020  
E-mail: [sales@macautomation.com](mailto:sales@macautomation.com)  
[www.macautomation.com](http://www.macautomation.com)

## THE EXPERT IN "PARTS MANAGEMENT SYSTEMS"

Width "W"	Length "A"	Height "B" @ 45° angle	Width "W"	Length "A"	Height "B" @ 45° angle	Elev. "C"	Elev. "D"
6"	3'	27.5"	6"	9'	78.3"	15.4"	7.5"
12"	4'	35.9"	12"	10'	86.8"	15.4"	7.5"
18"	5'	44.4"	18"	11'	95.3"	15.4"	7.5"
24"	6'	52.9"	24"	12'	103.8"	15.4"	7.5"
30"	7'	61.4"	30"	13'	112.3"	15.4"	7.5"
36"	8'	68.8"	36"	14'	120.7"	15.4"	7.5"
				15'	129.2"	15.4"	7.5"

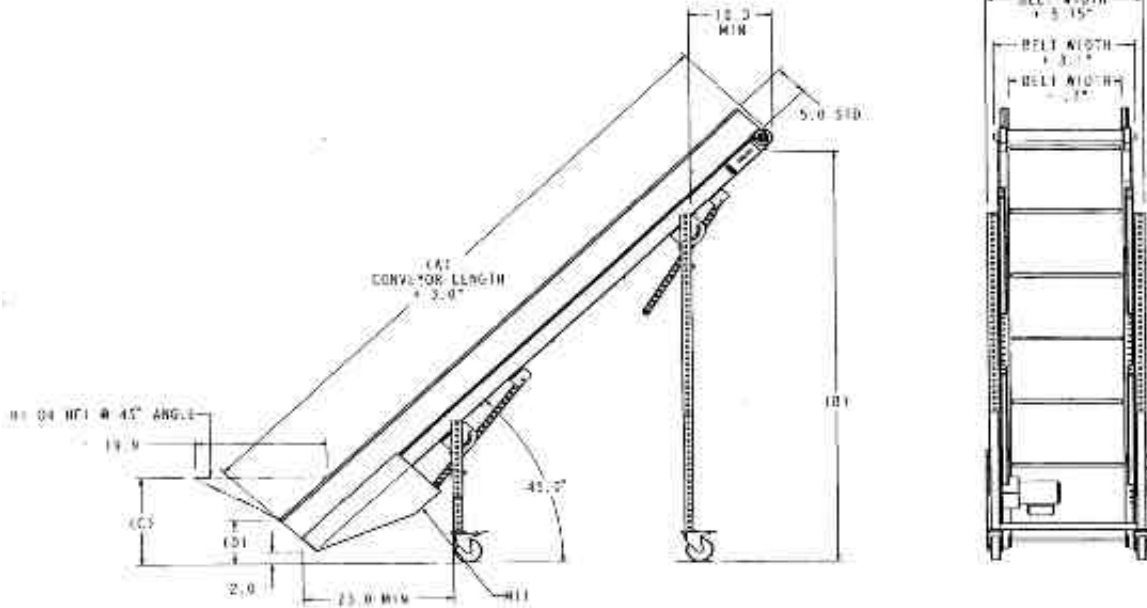

### Technical Information

<b>Frame:</b>	2.63" height, 13 gauge welded C channel steel frame fabricated with welded steel tubular cross members, optional steel slider bed for support
<b>Side Rails:</b>	5" extruded aluminum side rails with top return, overlap is .35" per side.
<b>Belt Widths:</b>	6", 12", 18", 24", 30", 36".
<b>Lengths:</b>	3' to 15' on 1' increments (standard)
<b>End Drive:</b>	Located at any one of the four corners, dependent upon length and application. Positions M3, M4, M13, M14 are preferred, M1, M2, M11, M12 are available if applicable, Side mounted drive is also available as an option. Standard drives are 120VAC/1/60 HZ motors.
<b>Speeds:</b>	22 FPM (standard), 9.5, 14.5, 32,FPM - available at no charge
<b>Pulleys:</b>	2.125" diameter drive and tail pulleys are both machined with trapezoidal crowns, shafts are 5/8" diameter and bearings are sealed self-aligning type. No lubrication is required.
<b>Take-up Assembly:</b>	Allows for 2.5 inches of take-up of belt adjustment
<b>Electrical Controls:</b>	NEMA 1 enclosure with push button manual motor starter with thermal overload protection and 12' of SJ 16/3 cord with plug for 120VAC input power as standard.
<b>Supports:</b>	Various telescoping legs, steel constructed with adjustable heights available
<b>Paint:</b>	MAC metallic Silver (other colors available as options)