

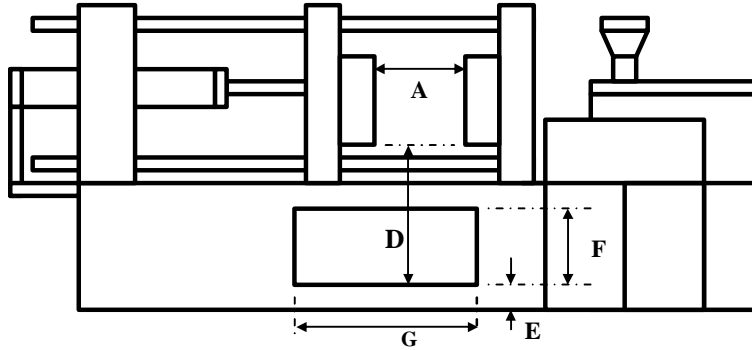

The Specialist in "Parts Management Systems"

MAC AUTOMATION – S1 Sorter

| | | | | | |
|-----------------|-------|--------------------------|--|---------------|--|
| Company: | | Address: | | | |
| Contact: | | City, State, Zip: | | | |
| Phone: | () - | Rep / Dist.: | | Ph/Fx: | |
| Fax: | () - | Salesman: | | | |
| E-Mail: | | E-Mail: | | | |

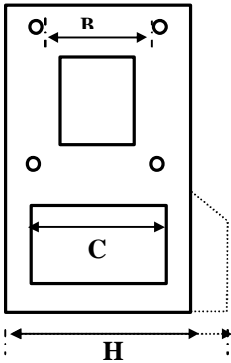

Please fill in as many dimensions as possible using inches.
Note: "A" = Mold Open when operating.

- "A" = _____
- "B" = _____
- "C" = _____
- "D" = _____
- "E" = _____
- "F" = _____
- "G" = _____

Please describe how you plan to use the S1-Sorter below. Will you be discharging:

S1 - Sorter

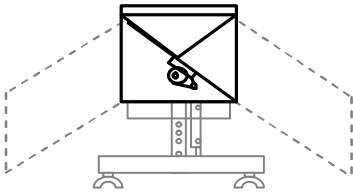

- > Fixed angle extensions
- > Adjustable leg stand

Operator Side: Good parts Bad Parts With Runners? Not at all

Into a: Container Conveyor Other _____

Container Dimensions: L: _____ W: _____ H: _____

Conveyor Specifics: Belt height: _____ Width: _____

Non-Operator Side: Good parts Bad Parts With Runners? Not at all

Into a: Container Conveyor Other _____

Container Dimensions: L: _____ W: _____ H: _____

Conveyor Specifics: Belt height: _____ Width: _____

Under the Press: Good parts Bad Parts With Runners? Not at all

Into a: Container Conveyor Other _____

Container Dimensions: L: _____ W: _____ H: _____

Conveyor Specifics: Belt height: _____ Width: _____

Are there any obstructions on either side?:

No Yes, Please describe: _____

What signal will be provided to divert the tray?: Dry Contact (Std): _____ 24VDC: _____ Other: _____

- Optional Extensions - No Extension 1 side 2 sides

Desired Extension Length:

6" 12"

18" Other _____

Custom charges may apply for lengths over 18"

OCSR1 - Sorter

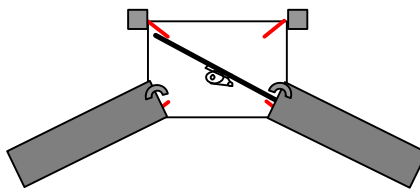

- > Quick Change Rail System
- > Adjustable angle extensions

- Angles (If Extensions are chosen)

Adjustable Angles (Standard)

Fixed Angle: 25° 30°

Other _____

Custom charges may apply for angles over 30°



The Specialist in "Parts Management Systems"

- **Optional Leg Stand** - No Leg Stand Desired

Required Height From The Floor?:

- 7" 7" - 12"
- 12" - 20" Other: _____

Custom charges may apply for lengths over 20".

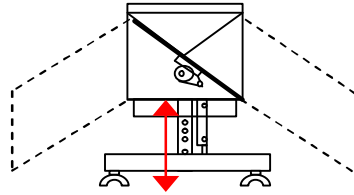

- **Optional Flared Top** - (Not available with Quick Change Rails)

No Flares Desired

Desired Flare Length?:

- "A":** 4" 6" 8" Other: _____
- "B":** 4" 6" 8" Other: _____

"A" & "B" are normally the same length. Custom charges may apply for lengths over 8".

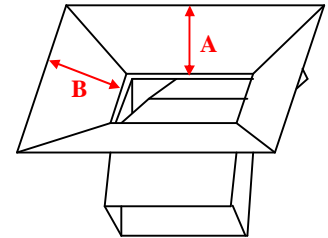
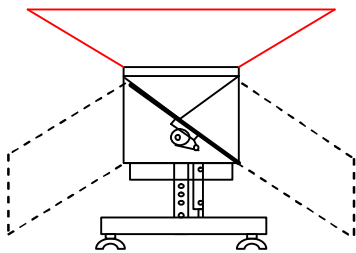

- **Optional Quick-Change Rail System** - Yes No

Patent Pending

What is the width of your Press?:

- Up to 36" Wide (QCRA1)
- Up to 48" Wide (QCRA2)
- Other

This system mounts to the press with our "Sliding Track System"

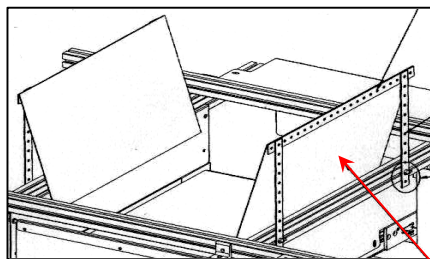
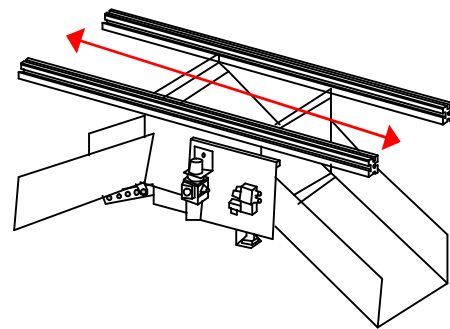
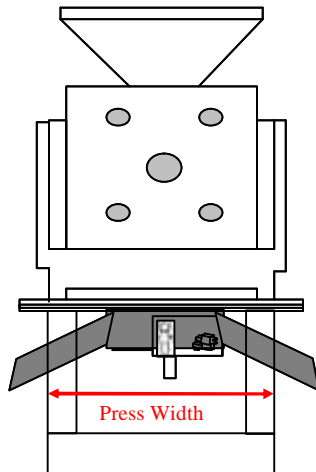
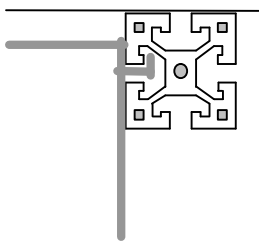

Quick-Change Part Containment – These components are used to create custom part containment. This is designed for the end-user to cut to fit. Includes standard hardware.

- Yes, Please include this package on my Quotation.
- No, I am not interested in this optional package.

Quick Change Part Containment (QCPC). Serves as a Hopper for the QCRS System