

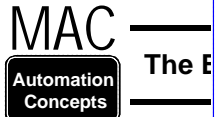

The Specialist in "Parts Management Systems"



Deleted:

PRESS DIMENSION FORM

Company:		Address:			
Contact:		City, State, Zip:			
Phone:	() -	Rep / Dist.:		Ph/Fx:	
Fax:	() -	Salesman:			
E-Mail:		E-Mail:			

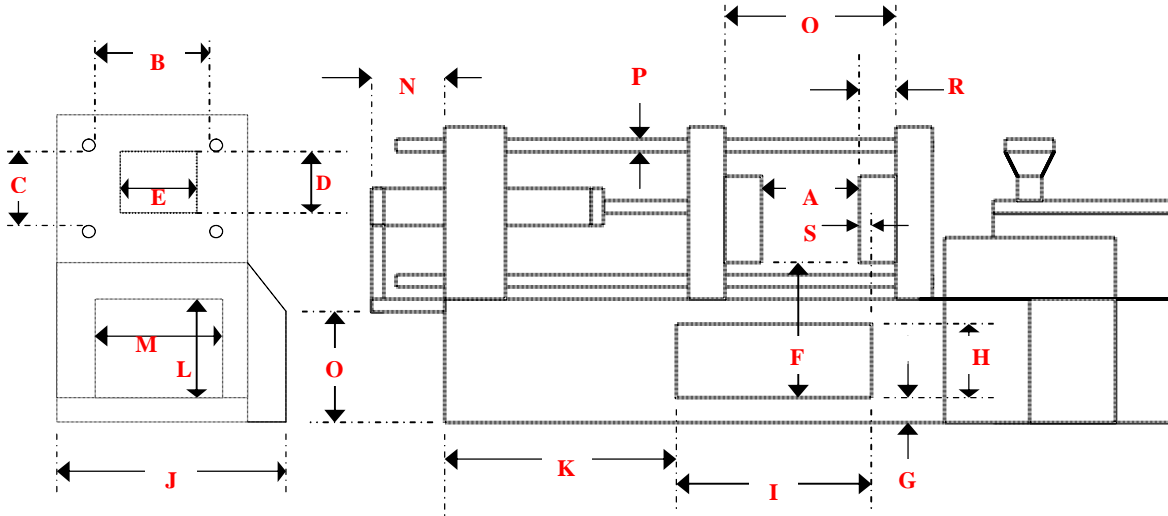

Please complete the following to the best of your knowledge, based on the diagram above.

Dimensions are in: Inches or Millimeters (Please circle one).

A		Mold Open
B		Width Between Tie-Bars
C		Height Between Tie-Bars
D		Mold Height
E		Mold Width
F		Mold To Machine Base
G		Base To Floor
H		Base To Frame
I		Length of Opening
J		Width of Opening

K		Base To Opening
L		Height of Opening
M		Width of End Opening
N		Length of Overhang
O		Overhang To Floor
P		Tie-Bar Diameter
Q		Platen To Platen
R		Mold Thickness
S		Mold Offset