

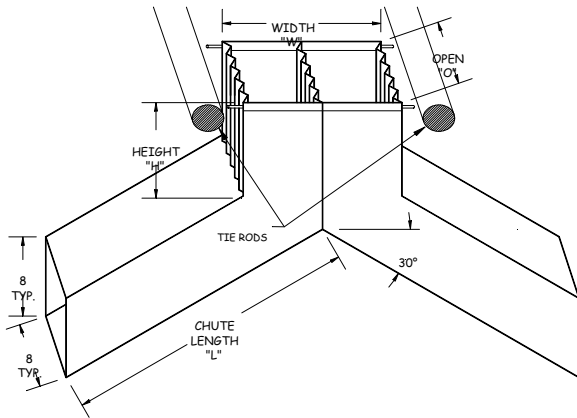

The Expert in "Parts Management Systems"

## Front/Rear Guideskirt – Quote Request Form

1. Mold Opening (daylight): \_\_\_\_\_ (max is 24")
2. (A) Width between Tie Rods: \_\_\_\_\_
3. (B) Width between Frame: \_\_\_\_\_
4. (C) Clearance Height (chute): \_\_\_\_\_
5. (D) Machine Clearance mold to base: \_\_\_\_\_
6. (E) Base to floor: \_\_\_\_\_
7. (F) Width of base: \_\_\_\_\_
8. (G) Desired extension past base: \_\_\_\_\_
9. (H) Desired discharge height: \_\_\_\_\_
10. Size of parts: \_\_\_\_\_ L x \_\_\_\_\_ W x \_\_\_\_\_ H
11. Runner system:  No  Yes
12. Size: \_\_\_\_\_
13. Do you require high temp material (for parts over 180°):  No  Yes
14. Quantity: \_\_\_\_\_

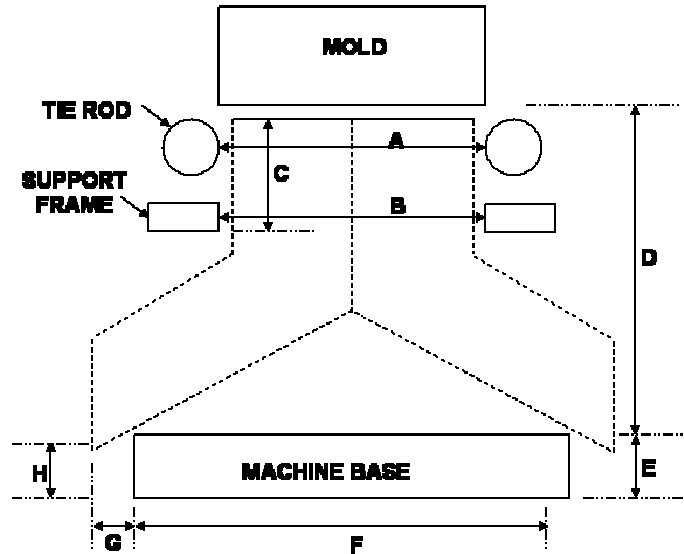

**ALL dimensions must be completed in order for a Quote to be given.**

All guideskirts come with mounting hardware. Hardware includes straight brackets (for attaching to side of mold) and right angle brackets (for mounting below the mold).

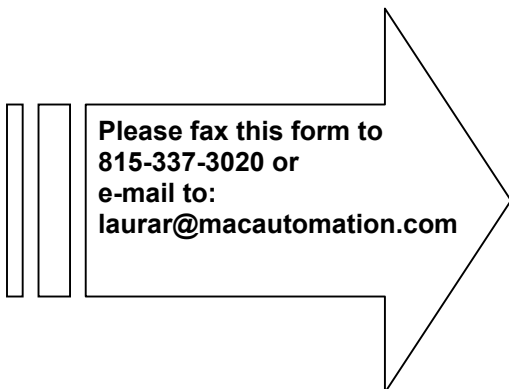

Please fax this form to  
**815-337-3020** or  
 e-mail to:  
**laurar@macautomation.com**

Company Name \_\_\_\_\_

Contact Person \_\_\_\_\_

Address \_\_\_\_\_

City, State, Zip \_\_\_\_\_, \_\_\_\_\_, \_\_\_\_\_

Phone, Fax ( ) - , ( ) - \_\_\_\_\_

E-mail \_\_\_\_\_@\_\_\_\_\_