

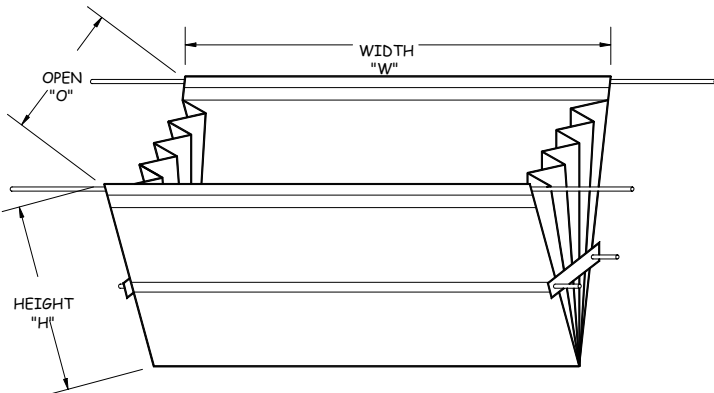

The Expert in "Parts Management Systems"

Delayed Drop Guideskirt – Quote Request Form

1. Mold Opening (daylight): _____
2. (A) Width between Tie Rods: _____
3. (B) Width between Frame: _____
4. (H) Desired height of guideskirt: _____
5. (C) Machine Clearance mold to base: _____
6. Size of parts: _____ L x _____ W x _____ H
7. Number of cavities: _____
8. Runner system: No Yes
9. Size: _____
10. Do you require a divider: No One Two Three
11. Do you require high temp material (for parts over 180°): No Yes
12. Quantity: _____

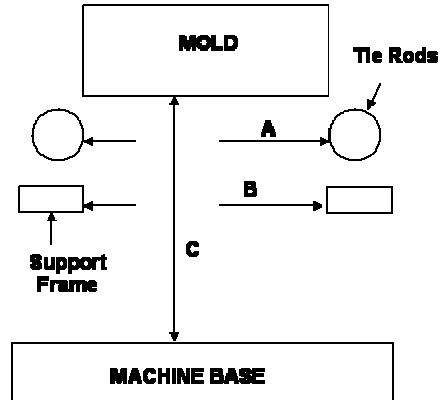

Delayed drops have metal side plates sewn into sides to keep sides rigid.

ALL dimensions must be completed in order for a Quote to be given.

All guideskirts come with mounting hardware. Hardware includes straight brackets (for attaching to side of mold) and right angle brackets (for mounting below the mold).

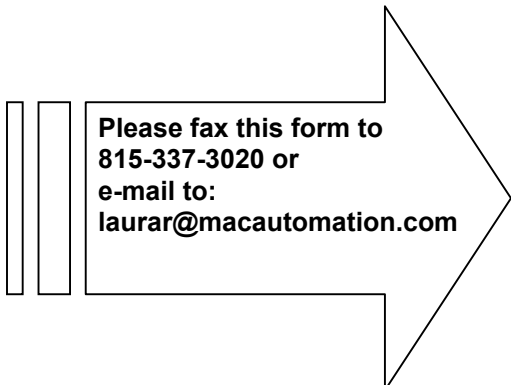

Company Name _____

Contact Person _____

Address _____

City, State, Zip _____, _____, _____

Phone, Fax () - , () - _____

E-mail _____@_____